

## ORIGINAL INSTRUCTIONS

# SLCS\* and SLCS\*/35 Safety Light Curtains

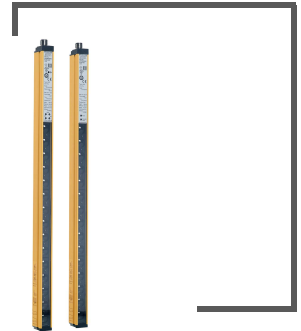

UL File Number: E215245



With regard to the supply of products, the current issue of the following document is applicable: The General Terms of Delivery for Products and Services of the Electrical Industry, published by the Central Association of the Electrical Industry (Zentralverband Elektrotechnik und Elektroindustrie (ZVEI) e.V.) in its most recent version as well as the supplementary clause: "Expanded reservation of proprietorship"

<b>1</b>	<b>Introduction.....</b>	<b>7</b>
1.1	Content of this Document .....	7
1.2	Symbols Used.....	7
<b>2</b>	<b>Safety information .....</b>	<b>9</b>
<b>3</b>	<b>Product Description .....</b>	<b>11</b>
3.1	Use and Application.....	11
3.2	Indicators and Operating Controls .....	13
3.3	Interfaces and Connections .....	14
3.4	Scope of Delivery.....	15
<b>4</b>	<b>Installation.....</b>	<b>16</b>
4.1	Planning and Preparation.....	16
4.2	Mounting.....	20
4.3	Reflection.....	23
4.4	Connection and Operating Mode Setting.....	24
4.4.1	Signal Outputs on the Receiver Unit.....	25
4.4.2	Signal Inputs on the Transmitter Unit .....	26
4.4.3	Signal inputs on the Receiver Unit .....	27
4.4.4	Typical Circuits .....	29
<b>5</b>	<b>Commissioning.....</b>	<b>30</b>
5.1	Functional Testing .....	30
5.2	Multiple Positions .....	31
<b>6</b>	<b>Maintenance and Repair .....</b>	<b>33</b>
6.1	Maintenance .....	33
6.2	Periodic Checks .....	33
6.3	Repairs .....	34
<b>7</b>	<b>Troubleshooting.....</b>	<b>35</b>
7.1	Troubleshooting .....	35
<b>8</b>	<b>Appendix .....</b>	<b>37</b>
8.1	Technical Data .....	37
8.1.1	Standards and Key Data for Functional Safety.....	40
8.2	Profile Lengths and Mass.....	42
8.3	Dimension Drawings .....	43
8.4	Type Code.....	44
8.5	Application Checklist.....	49

<b>8.6</b>	<b>Accessories.....</b>	<b>51</b>
<b>8.6.1</b>	<b>Mounting Aid OMH-SLCT-01 .....</b>	<b>57</b>
<b>8.6.2</b>	<b>Mounting Aid OMH-SLCT-02 .....</b>	<b>57</b>
<b>8.6.3</b>	<b>Mounting brackets OMH-SLCT-03 and OMH-SLCT-04 .....</b>	<b>58</b>
<b>8.6.4</b>	<b>Mounting Aid OMH-SLCT-05 .....</b>	<b>58</b>
<b>8.6.5</b>	<b>OMH-SLCT-12 -500 Muting Arm with Round Rod.....</b>	<b>58</b>
<b>8.6.6</b>	<b>OMH-07-01 Mounting Bracket for Circular Profiles .....</b>	<b>58</b>
<b>8.6.7</b>	<b>OMH-SLCT-100-xxxx Mounting Profile for Floor Mounting .....</b>	<b>58</b>
<b>8.6.8</b>	<b>OMH-SLCT-110-xxxx Mounting Profile with Decorative Cover (Front) ...</b>	<b>59</b>
<b>8.6.9</b>	<b>OMH-SLCT-120-xxx Lateral Protective Covers for Mounting Profile .....</b>	<b>59</b>
<b>8.6.10</b>	<b>OMH-SLCT-200 Floor Mount for Soil Column/Mounting Profile .....</b>	<b>59</b>
<b>8.6.11</b>	<b>SLCT-M-01-xxxx Inclined Mirror for 90° Deflection .....</b>	<b>59</b>
<b>8.6.12</b>	<b>Alignment Aid .....</b>	<b>60</b>
<b>8.6.13</b>	<b>Test Rod .....</b>	<b>60</b>
<b>8.6.14</b>	<b>Connection Cables .....</b>	<b>61</b>

# 1 Introduction

## 1.1 Content of this Document

This document contains safety-relevant information for usage of the device. You need this information to use your product throughout the applicable stages of the product life cycle. These can include the following:

- Product identification
- Delivery, transport, and storage
- Mounting and installation
- Commissioning and operation
- Maintenance and repair
- Troubleshooting
- Dismounting
- Disposal



### **Note!**

For full information on the product, refer to the further documentation on the Internet at [www.pepperl-fuchs.com](http://www.pepperl-fuchs.com).

The documentation consists of the following parts:

- Original instructions (present document)
- EU declaration of conformity
- Datasheet

For more information about Pepperl+Fuchs products with functional safety, see [www.pepperl-fuchs.com/sil](http://www.pepperl-fuchs.com/sil).

## 1.2 Symbols Used

This document contains symbols for the identification of warning messages and of informative messages.

### **Warning Messages**

You will find warning messages, whenever dangers may arise from your actions. It is mandatory that you observe these warning messages for your personal safety and in order to avoid property damage.

Depending on the risk level, the warning messages are displayed in descending order as follows:

***Danger!***

This symbol indicates an imminent danger.

Non-observance will result in personal injury or death.

***Warning!***

This symbol indicates a possible fault or danger.

Non-observance may cause personal injury or serious property damage.

***Caution!***

This symbol indicates a possible fault.

Non-observance could interrupt the device and any connected systems and plants, or result in their complete failure.

**Informative Symbols*****Note!***

This symbol brings important information to your attention.

**Action**

This symbol indicates a paragraph with instructions. You are prompted to perform an action or a sequence of actions.

## 2 Safety Information

Read the following information carefully and follow this information when working with the device. Failure to observe the safety information and warning messages in this documentation can lead to malfunctions of the safety devices of the machines or plants in which they are fitted.

This can result in serious personal injury or death.

### **Target Group, Personnel**

Responsibility for planning, assembly, commissioning, operation, maintenance, and dismantling lies with the plant operator.

The personnel must be appropriately trained and qualified in order to carry out mounting, installation, commissioning, operation, maintenance, and dismantling of the device. The trained and qualified personnel must have read and understood the instruction manual.

Prior to using the product make yourself familiar with it. Read the instruction manual carefully.

### **Reference to Further Documentation**

Observe laws, standards, and directives applicable to the intended use and the operating location.

If you use the device in safety-related applications, observe the requirements for functional safety. You can find these requirements in the functional safety documentation under [www.pepperl-fuchs.com](http://www.pepperl-fuchs.com).

### **Intended Use**

The device is only approved for appropriate and intended use. Ignoring these instructions will void any warranty and absolve the manufacturer from any liability.

If you use the device in safety-related applications, observe the information for safety function and safe state.

The safety light curtain may only be used in accordance with its intended purpose as noncontact electro-sensitive protective equipment (ESPE) for securing sources of danger and hazardous areas on machines and plants.

Ensure that this device is used only in accordance with the technical specification described in these instructions. The device must not be used outdoors or in an explosion-hazardous area.

### **Plant design**

Before selecting and using the product, an assessment must be made to determine whether this product is suitable for the intended application. Pepperl+Fuchs has no influence on the selection and use of this product. The warranty therefore only covers the consistent quality of the product.

### **Mounting and installation**

If you install the device in safety-related applications, observe the requirements for functional safety.

### **Operation, maintenance, repair**

If you are operating the device in applications related to safety, note the requirements for functional safety.

Do not remove the nameplate.

Do not remove the warning markings.

Record the results of inspections and maintenance carefully.

Do not repair, modify, or manipulate the device.

If there is a defect, always replace the device with an original device.

Only use accessories specified by the manufacturer.

### **Delivery, Transport, Disposal**

Keep the original packaging. Always store and transport the device in the original packaging.

Disposing of device, packaging, and possibly contained batteries must be in compliance with the applicable laws and guidelines of the respective country.

## 3 Product Description

### 3.1 Use and Application

#### **Product Description**

The SLCS safety light curtain is noncontact electro-sensitive protective equipment (ESPE) for securing sources of danger and hazardous areas.

The SLCS consists of a transmitter and a receiver unit. The protection field is formed by infrared light beams sent from the transmitter to the receiver. The offset between the individual light beams determines the minimum obstruction size (14, 30, 60, or 90 mm) that can be reliably detected in the entire protection field range.

The transmitter unit contains a certain number of transmitter diodes that emit protective beams. The number of transmitter diodes is determined by the protection field height and size of the obstacle. The function mode A/B enables the use of 2 adjacent safety light curtains.

The receiver unit detects the transmission beams, controls the two protective OSSD (Output Signal Switching Devices) safety outputs and carries out tests to ensure safety.

In addition to the displays behind the front panel of the receiver unit, there is also a PNP output, which indicates operational readiness, a dirty lens, or fault states. If an internal fault occurs in the receiver unit, this output switches on and off at a frequency of 5 Hz. If an external fault occurs, this output switches on and off at a frequency of 1 Hz. If the received signal is too weak (e.g., due to a dirty lens), the output switches on and off at a frequency of 2.5 Hz.

The test input on the transmitter initiates a test sequence. Activate the input by applying 24 VDC to the input for a defined time span.

The relay monitor (RM) and restart (RI) inputs allow monitoring of the switching elements connected externally to the OSSDs and activation of the startup/restart interlock function.

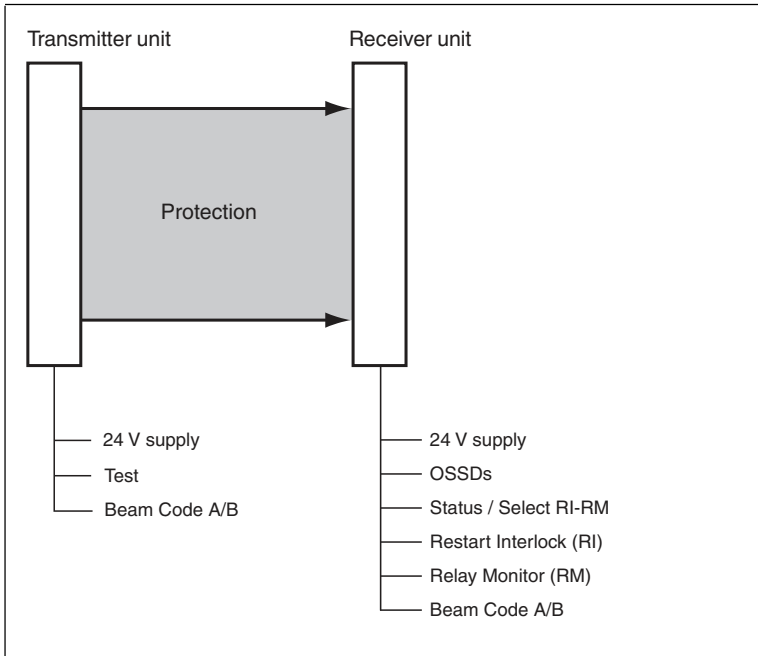

Figure 3.1 Schematic diagram of a detection device

### Product Features

- Type 4 ESPE in accordance with IEC/EN 61496-1
- Self-testing
- Obstacle size, depending on type, 14 mm, 30 mm, 60 mm, 90 mm
- Protection field heights up to 1200 mm (SCLS14)
- Protection field heights up to 2400 mm (SLCS30, SLCS60, SLCS90)
- Protection field grid, 100 mm (SLCS14, SLCS30)
- Protection field grid, 300 mm (SLCS60, SLCS90)
- Selectable startup/restart interlock
- Selectable relay monitor
- Simple layout
- Two OSSDs

### Further information about the product

The following information about the SLCS series is provided in the appendix at the end of this document:

Technical data: see chapter 8.1.

Available profile lengths/dimensions: see chapter 8.2.

Dimensional drawings: see chapter 8.3.

Product characteristics by type code: see chapter 8.4.

Available accessories: see chapter 8.6.

### 3.2 Indicators and Operating Controls

The transmitter has two LEDs to display its operating status.

The receiver has five LEDs to display its operating status.

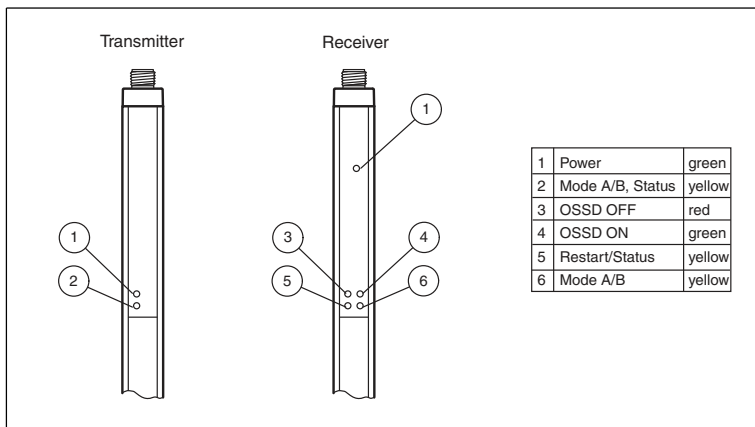

Figure 3.2 Displays on the transmitter and receiver units

No.	Designation	LED Color	Meaning
1	Power LED	Green	Transmitter and receiver units operating
2	A/B mode, status	Yellow	Indicator flashing at 1 Hz: testing time exceeded or A/B mode input level change  Indicator flashing at 5 Hz: internal fault
3	OSSD OFF	Red	OSSDs switched off
4	OSSD ON	Green	OSSDs switched on
5	Restart/status	Yellow	On: protection field free: system ready to start Indicator flashing at 1 Hz: external fault Indicator flashing at 2.5 Hz: insufficient functional reserve Indicator flashing at 5 Hz: internal fault
6	Mode A/B	Yellow	Off: mode A On: mode B

### 3.3 Interfaces and Connections

The electrical connections of the safety light curtain are made using M12 plug-in connectors. The transmitter has a 4-pin connector and the receiver an 8-pin plug-in connector.

Connect the power supply and, depending on the application, the test signal to the transmitter unit. The mode can also be selected via the A/B mode input.

Connect the power supply, the fail-safe outputs (OSSD), the status/select output and the inputs for the startup enable, relay monitor and A/B mode to the receiver unit.

The housing profile is connected internally with approx. 2.3 MOhm// 33 nF each at +24 V and 0 V. Internal varistors limit any surges that occur at approx. 85 V. A separate grounding or connection between the housing and functional ground is not required.

#### Transmitter



Figure 3.3 Pin assignment transmitter unit

- 1 24 V DC
- 2 Mode A/B
- 3 0 V DC
- 4 Test

#### Receiver

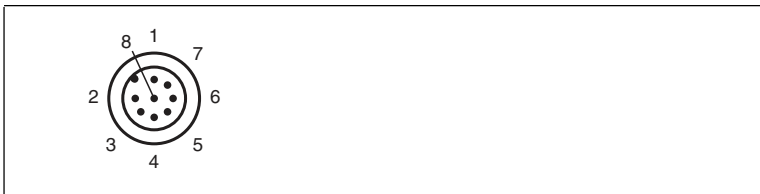
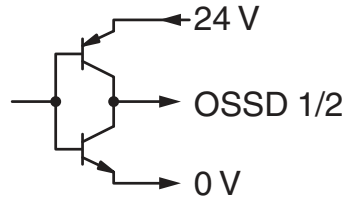

Figure 3.4 Pin assignment receiver unit

- 1 Restart Interlock (RI)
- 2 24 V DC
- 3 Relaismonitor (RM)
- 4 Status / Select RI-RM
- 5 OSSD 1
- 6 OSSD 2
- 7 0 V DC
- 8 Mode A/B



### 3.4 Scope of Delivery

The scope of delivery includes:

**Scope of delivery: transmitter**

- Transmitter

**Scope of delivery: receiver**

- Receiver
- I/O Manual
- Test rod

Bracket and cable are not included in the scope of delivery. Visit [www.pepperl-fuchs.com](http://www.pepperl-fuchs.com) for a selection of compatible fixing brackets and recommended cables.

## 4 Installation

### 4.1 Planning and preparation



#### **Warning!**

Danger to life due to ineffective protective equipment

Improper or incorrect alignment, fixing, and connection to machine control can impair the effectiveness of the protective function.

- Note the applicable standards, guidelines, and legal regulations for the equipment of machine and plants with protective equipment.
- Position the protective equipment to prevent persons from being able to reach or walk behind it, climb over or under, or otherwise bypass the equipment in any way.
- Use appropriate safety distances to take into account the response times and lag times of the components in the safety chain.
- Secure the protective equipment against manipulation or deliberate deactivation.

#### **Safety distance**

A minimum distance must be maintained between the protection field and the hazardous area to ensure potentially dangerous movements are brought to a stop before contact with a person is possible.

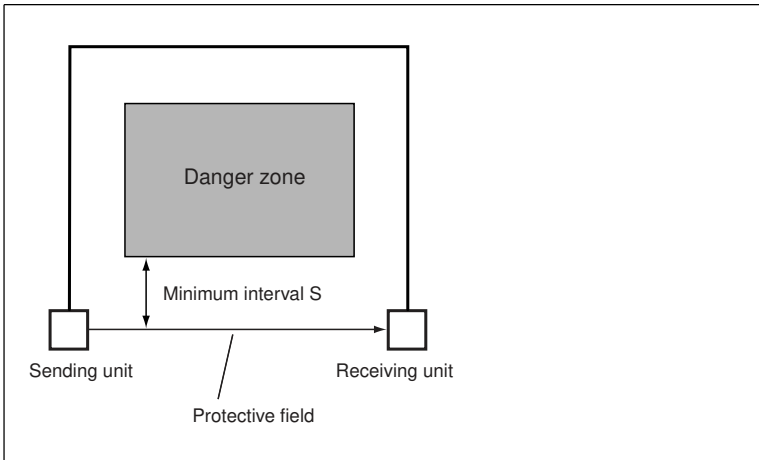

Figure 4.1 Minimum distance between protection field and hazardous area

This distance is calculated from the lag time of the machine, the response time of the safety system, and the speed of movement of the person entering the hazardous area (ISO/EN 13855).

To comply with the necessary distances in the event that the protection field spreads, please refer to Table 1 of ISO/EN 13855 to check the minimum distance for a vertically positioned protection field. If you read the value 0 from the table, you can determine the minimum distance with the following formula:

$$S = K \times T + C$$

Where, for a **protection field aligned vertically** to the hazardous area:

S	Minimum safety distance in mm, i.e. the distance between hazardous area and protection field				
K	Constant in mm/s for the speed of approach, based on the detection capacity of the sensor				
T	Total response time of the protective device in s ( $T = t_1 + t_2$ )				
$t_1$	Response time of the protective equipment. See the table below.				
$t_2$	Machine lag time				
C	Additional distance in mm, see table				
	Number of beams/resolution	14 mm	30 mm	60 mm	90 mm
		0 mm	128 mm	850 mm	850 mm
For arrangements other than a perpendicular alignment of the protection field, see also EN ISO 13855.					

### Response times of the safety light curtain

The safety light curtain response time is shown on the rating plate.

Protection field height [mm]	Switch-on delay [ms]						
	SLCS14-*	SLCS30-*	SLCS30-*/35	SLCS60-*	SLCS60-*/35	SLCS90-*	SLCS90-*/35
100	11	8	9	-	-	-	-
200	15	10	11	-	-	-	-
300	19	11	12	9	10	8	8
400	23	12	14	-	-	-	-
500	26	14	16	-	-	-	-
600	30	15	17	11	12	10	10
700	34	16	19	-	-	-	-
800	38	17	21	-	-	-	-
900	42	19	23	13	15	11	11
1000	46	20	25	-	-	-	-
1100	50	21	26	-	-	-	-
1200	54	23	28	15	17	12	12
1300	-	24	30	-	-	-	-
1400	-	25	32	-	-	-	-
1500	-	26	33	17	20	14	14
1600	-	28	35	-	-	-	-
1700	-	29	37	-	-	-	-
1800	-	30	38	19	23	15	15
1900	-	32	40	-	-	-	-
2000	-	33	42	-	-	-	-
2100	-	34	43	21	25	16	16
2200	-	35	45	-	-	-	-
2300	-	37	47	-	-	-	-
2400	-	38	48	23	28	17	17

Table 4.1 Response times of the SLCS protective equipment

271694.2017-11

The switch-on time after beam interruption without a restart function is between 80 ms ... 200 ms. The switch-on time depends on the number of protective beams.

**Notes on setting up safety light curtains**

The protective equipment must be arranged in such a manner that it is impossible to reach over, reach under, or walk behind the protection field. If the distance from the safety device is too great, additional safety equipment must be put in place (see illustration below).

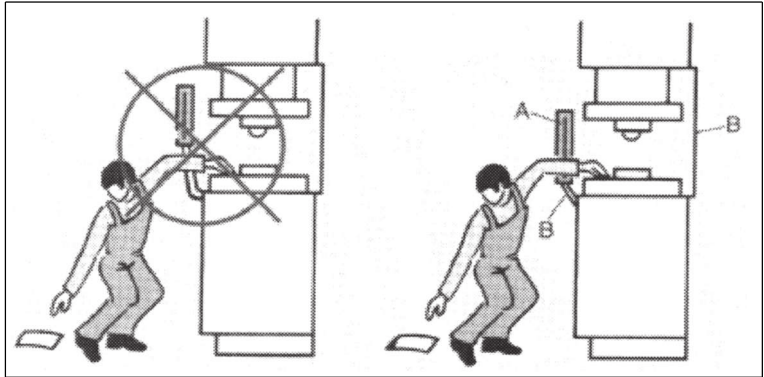

**Reaching over**

The user must not be able to reach over the protection field and into the hazardous area (A: protection field, B: mechanical protection).

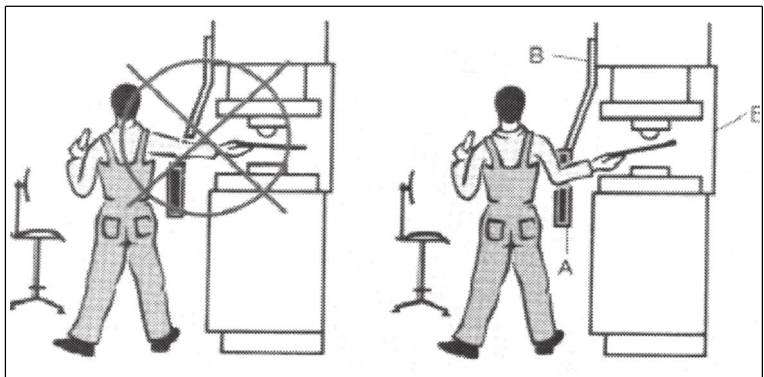

**Walking behind**

The machine operator must not be able to walk between the light curtain and into the hazardous area (A: protection field, B: mechanical protection).

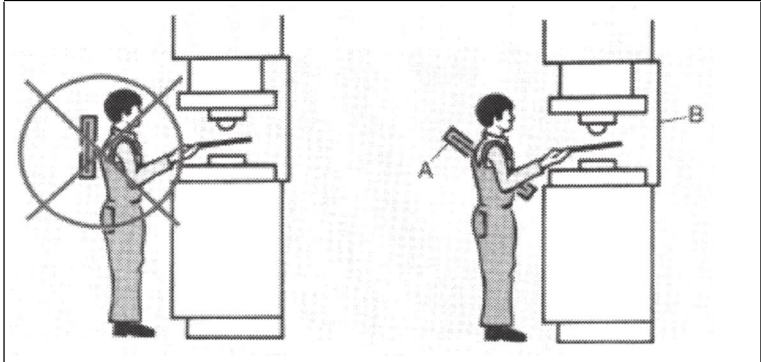

## 4.2 Mounting



### **Warning!**

Danger to life due to ineffective protective equipment

Improper or incorrect alignment, fixing, and connection to machine control can impair the effectiveness of the protective function.

- Check the positioning of the protective equipment and ensure that it is not possible for persons to reach or walk behind it, climb over, under or otherwise bypass the protective equipment.
- Check the safety distances and the lag times of the components in the safety chain.
- Check that the protective equipment cannot be easily manipulated or disabled.

Various mounting materials for mounting on machines or in the field are available for securing the safety light curtain. See chapter 8.6.

If you are planning to mount a safety light curtain with an increased detection range, we recommend that you use assembly profiles for floor mounting from our range of accessories. See chapter 8.6.7.

### Mounting

1. Align the transmitter and receiver so that they are parallel with one another with both units at the same height.
2. Align the transmitters and receivers parallel with one another.
3. The stability alarm indicator helps with correct alignment.

When installing the safety light curtain in a source of danger, a minimum distance must be maintained between the protection field and the hazardous zone. This distance will guarantee that movements that pose a danger to a person can be brought to a stop before that person comes in contact with the source of danger.

The distance is calculated from the lag time of the machine, the response time of the safety light curtain, and the speed of movement of the person entering the hazardous area (EN ISO/EB 13855, ISO/EN 13857).

### Vertical approach

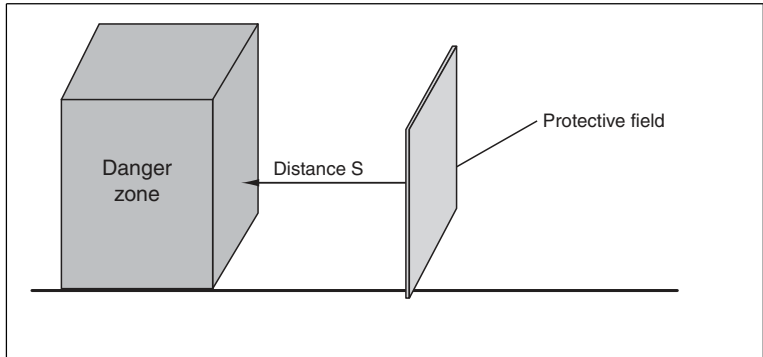

Figure 4.2 Explanation of the safety distance in a vertical arrangement of the protective field

If  $K = 2000 \text{ mm/s}$  and  $C = 0 \text{ mm}$ , for example with SLCS14...  
or  $C = 128 \text{ mm}$  with e.g. SLCS30...  
, the calculation formula for a distance  $S$  of 105 mm up to and including 500 mm is as follows:

$$S = 2000 \text{ mm/s} * (t_1 + t_2) + C$$



**Note!**

If  $S$  is greater than 500 mm, then  $K = 1600 \text{ mm/s}$  must be used for calculations:

$$S = 1600 \text{ mm/s} * (t_1 + t_2) + C$$

$S$  must be at least 500 mm. Lower results must be corrected to a minimum distance of 500 mm.

Example: vertical arrangement

$$t_1 = 50 \text{ ms}$$

$$t_2 = 300 \text{ ms}$$

Hand protection  $C = 128 \text{ mm}$

$$S = 2000 \text{ mm/s} * (350 * 10^{-3} \text{ s}) + 128 \text{ mm}$$

$$S = 700 \text{ mm} + 128 \text{ mm} = \mathbf{828 \text{ mm}}$$

As  $S$  is  $> 500 \text{ mm}$ , a smaller value can also be determined:

$$S = 1600 \text{ mm/s} * (350 * 10^{-3} \text{ s}) + 128 \text{ mm} = 688 \text{ mm}$$

The minimum distance between protection field and hazardous area must therefore be **688 mm**.

### Parallel approach

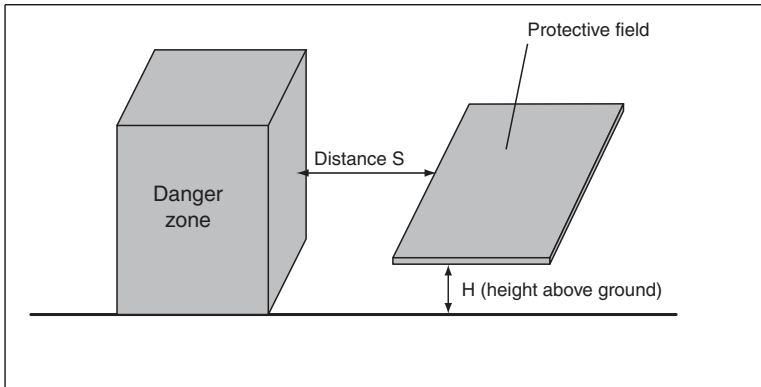

Figure 4.3 Explanation of the safety distance in a horizontal arrangement of the protective field

If the safety light curtain is aligned in a horizontal position, the safety distance  $S$  will also depend on the height of the light curtain above the floor. The maximum height  $H$  must not exceed 1000 mm.



#### ***Danger!***

The ability to circumvent the protective function presents a danger to life

If the height  $H$  is greater than 300 mm, there is a risk that access underneath the safety light curtain will be possible.

For a height  $H$  of 300 mm and above, consider the additional access potential in the risk analysis or ensure that additional barriers are in place.

The safety distance is calculated as follows:

$$S = 1600 \text{ mm/s} \cdot (t_1 + t_2) + (1200 \text{ mm} - 0.4 H)$$

Therefore  $(1200 \text{ mm} - 0.4 H) \geq 850 \text{ mm}$  is required.

### 4.3 Reflection



**Danger!**

Danger to life due to reflection

If you do not comply with the minimum distances, objects or persons cannot be safely detected in the beams of the protective equipment.

- When aligning the protective equipment, ensure that the minimum distance to reflective objects or surfaces on all sides of the protection field is observed. The required minimum distances are listed in the table in this documentation.
- Do not operate the protective equipment if diffuse dispersive media are present.
- Perform test rod tests throughout the whole area of the protection field. See chapter 5. See chapter 6.2.

Ensure that there are no reflective objects within the transmitter or receiver path that could deflect the beams around an obstruction (EN 61496-2).

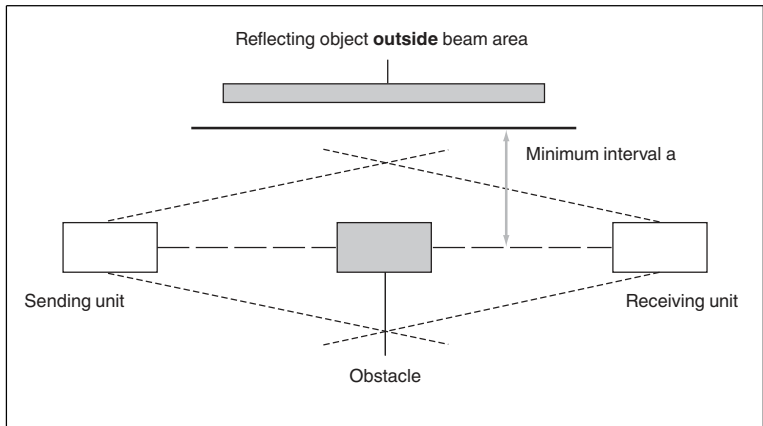

Figure 4.4 Explanation to the risk of radiation protection of remirroring

### Minimum distance between protection field and reflective surfaces

Protection field width [m]	Minimum distance [mm]
0.2 ... 3.0	135
4.0	175
5.0	220
6.0	265
8.0	350
10	450
15	660
20	880



#### **Danger!**

Danger to life due to indirect dispersion of light during operation below the specific minimum range

If you operate the protective equipment below its specified minimum range, this can lead to reflection caused by reflective or dispersive objects outside the specified minimum distances. The resulting malfunction can cause a failure to detect persons or objects.

- Observe the minimum range of the protective equipment that you are using.
- Never operate the protective equipment below this specified minimum range!
- During mounting, also note that the conditions for light beam dispersion may change during operation, e.g. due to moving machine parts or optically dispersive media.

## 4.4 Connection and Operating Mode Setting

The supply voltage and the system settings can be switched on the transmitter unit and the receiver unit. The following operating mode settings are also available:

- **Startup interlock operating mode**
- **Relay monitor operating mode**
- **A/B operating mode**

### **Startup interlock operating mode**



#### **Note!**

When the input is open, the startup/restart interlock is activated.

The startup/restart interlock ensures that after the power supply has been turned on, or after an interruption in the protection field, the operational readiness state is indicated when the protection field is free. The startup release must then be activated so that the safety light curtain activates the OSSDs.

The function can be activated or deactivated at the 8-pin plug-in connector of the receiver SLCS.

An NC contact between the restart and +24 VDC input is required to trigger the startup/restart interlock. The startup/restart interlock function does not work if the restart input is bridged with the status/select output. If the input is not connected, the startup/restart interlock is activated (see chapter 4.4.4).

#### Relay monitor operating mode

The relay monitor input monitors the switching positions of the downstream relays. If the switching position of the relay does not match the signal from the OSSDs, the system switches to safe mode. The status LED indicates that safe mode is active.

The function can be activated or deactivated at the 8-pin plug-in connector of the receiver SLCS.

The two feedback contacts on the external switching elements must be placed between 24 VDC and the relay monitor input in order to activate the relay monitor. The relay monitor function is deactivated if the relay monitor input is bridged with to the status/select output.



#### **Note!**

An open relay monitor input results in a fault. The yellow indicator LED flashes at a frequency of 1 Hz in the event of a fault.

#### A/B operating mode

Operating mode A or operating mode B must be configured on both the transmitter and on the receiver. The modes are used to prevent cross-talk from adjacent SLCS safety light curtains.

### 4.4.1

#### Signal outputs on the receiver unit

##### Status/Select RI-RM output

The output indicates the same states as the restart/status indicator.

This signal output indicates operational readiness and is active when the protection field is free and startup enable can be activated in order to switch on the OSSD. Internal or external faults and a dirty lens, are also signaled at this output.

If an external fault occurs, the output switches on and off at a frequency of 1 Hz. The following faults may be the cause:

- Relay monitor faulty
- Low supply voltage
- Short or crossed circuits at the OSSD outputs and

- Level change at the mode input during operation

Internal faults cause the output to switch on and off at a frequency of 5 Hz.

If the safety light curtain is not adjusted correctly or the front lenses are not clean, the output switches on and off at a frequency of 2.5 Hz.

The output is also used to define the preset operating mode during startup. Bypassing this output to the restart and/or relay monitor inputs deactivates the relevant operating mode.

### OSSDs

The receiver has two safe outputs, which are short circuit and cross circuit proof. The OSSDs switch off as soon as a light beam is interrupted. Switching times, .

## 4.4.2

### Signal Inputs on the Transmitter Unit

#### Test input

Connect the test input to 24 VDC via an NC contact. The test function is triggered by opening the contact.



#### **Note!**

During operation without a startup/restart interlock, the test time must be limited to 150 ms.

The test input is used to start a complete test of the safety light curtain. During this process, the OSSDs are switched off and all system components are checked.

Fault messages from the transmitter unit are acknowledged by initiating a test.



#### **Note!**

A complete test is also carried out when the operating voltage is switched on. This also applies to the receiver unit, which does not have a test input.

The time constraints of the test signal must be maintained for a test to be successful ( → see Figure 4.5 on page 27). On an SLCS30-600 safety light curtain, for example, the time between the test requirement and the response to the OSSDs is a minimum of 6 ms and a maximum of 18 ms. A test input actuation time of less than 0.02 s or more than 2.4 s switches the transmitter to an error state.



#### **Note!**

In the case of a fault, the fault can be reset by activating the input once more for between 1.2 s and 2.4 s.

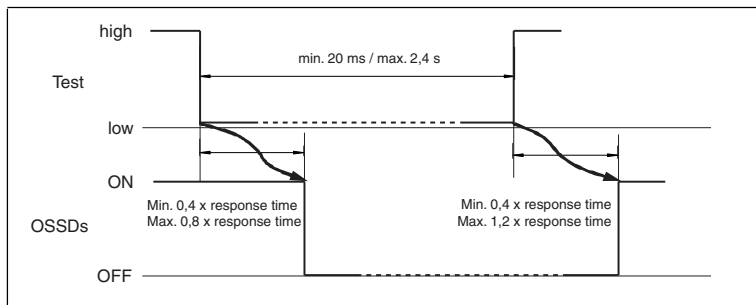

Figure 4.5 Graphs of the OSSD switching states when initiating a test or reset

### A/B mode input

If the input is open or connected to 0 V, the safety light curtain operates in mode A. The inputs must be connected to the supply voltage 24 VDC to switch to mode B.

After the supply voltage is switched on, the transmitter or receiver selects mode A or mode B, depending on the applied voltage.



#### **Note!**

Make sure that the transmitter and receiver are operating in the same mode.

If the level at the input changes during operation, this is identified as a fault and the system switches to safe mode.

### 4.4.3

#### Signal inputs on the receiver unit

Connect the restart (RI) and relay monitor inputs to the receiver unit with NC contacts that switch 24 VDC. The function is triggered if the external control contact is open for a defined period.

#### **Restart (RI), startup/restart interlock input**

The startup/restart interlock prevents the OSSDs from switching to ON after the protection field is cleared or after the supply voltage is turned on when the protection field is free. The safety function is only activated once the startup enable button has been pressed.

An NC contact that switches the supply voltage must be connected to the input to activate the safety function. If the start/restart interlock should be deactivated, the input must be bridged with the status/select output. An open input also activates the startup/restart interlock.

The input signal time is monitored and the actuation time should be active for between 0.2 s to 1.2 s.



#### **Note!**

In the case of a fault, the fault can be reset by pressing and holding the startup enable button for between 1.2 s and 2.4 s.

**Danger!**

Danger to life due to incorrectly positioned startup enable

If you install the button for the startup enable within the hazardous area or in a position from which the hazardous area is not visible, this may result in the button being pressed although personnel or objects are still located within the hazardous area.

- Mount the startup enable button in front of the hazardous area as follows:
  - It must not be possible to activate the startup enable from within the hazardous area, or to trigger a function that would mean the protection field is interrupted by pressing the button.
  - The hazardous area must be clearly visible from the location in which the button is pressed.

**Relay monitor input**

Auxiliary contacts on switching elements connected downstream of the OSSDs can be connected to the relay monitor input. This allows these elements to be monitored. Use NC contacts (see chapter 4.4.4). All monitored switching elements must be connected in series. One end of this series connection must be connected to the positive power supply and the other end to the relay monitor input.

The feedback contacts on the external switching elements must guarantee a reliable contact at a voltage of 20 VDC and a current of 5 mA.

**Danger!**

Danger to life due to electric shock

Insufficient separation distances can negate the safe separation of a SELV/PELV supply of the protective equipment. This can lead to a particularly high voltage on the device and present a danger to life.

The protection class III of the protective equipment and the necessary safe separation distance must be taken into account when designing the insulation coordination of the electrical installation or machine.

For more information, also see IEC 60204, IEC 60664 and IEC 61140 and the relevant national regulations.

If the external switching element is not activated within 200 ms, this is identified as a fault and safe mode is activated.

To disable the function, the input must be bridged with the status/select output. An open input also activates the relay monitor function.

**A/B mode input**

If the input is open or connected to 0 V, the safety light curtain operates in mode A. The inputs must be connected to the supply voltage 24 VDC to switch to mode B.

After the supply voltage is switched on, the transmitter or receiver selects mode A or mode B, depending on the applied voltage. Make sure that the transmitter and receiver are operating in the same mode.

If the level at the input changes during operation, this is identified as a fault and the system switches to safe mode.

#### 4.4.4 Typical circuits

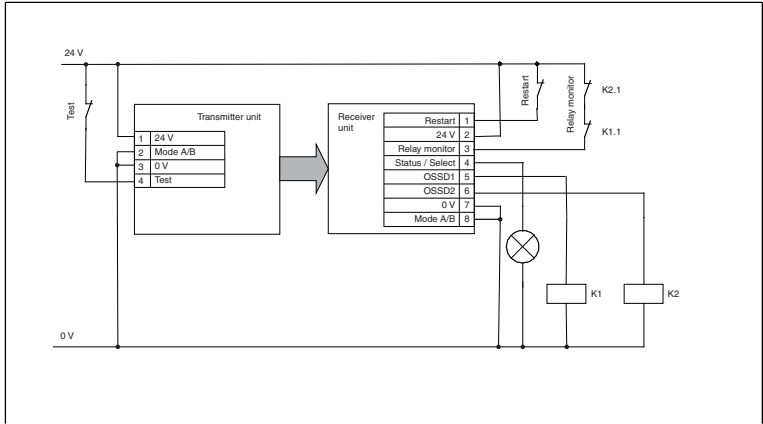

Figure 4.6 Connection example with relay monitor and restart in Mode A

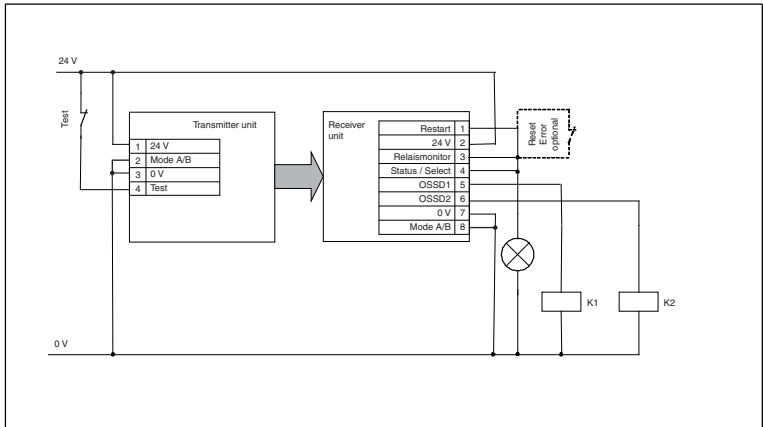

Figure 4.7 Connection example without relay monitor and without restart in Mode A

## 5 Commissioning

### 5.1 Functional Testing



#### Check the function of the transmitter and receiver

1. Check whether the transmitter and receiver are aligned parallel to one another and are at the same height.
2. Switch on the safety light curtain when the protection field is clear.
3. Adjust the transmitter and receiver so that the reception signal exceeds the functional reserve.  
↳ If the reception signal falls below the functional reserve, the yellow restart/status LED on the receiver flashes.
4. Check whether the two OSSD outputs are switching on correctly. The **Ready to start** message appears unless this operating mode is deactivated by an external circuit.
5. Use the supplied test rod to test the detection capability of the safety light curtain to identify any detection gaps caused by reflective surfaces. (see chapter 8.6.13).
6. Check the effectiveness of the switch-off function of the safety light curtain and the response time of the safety function when a beam is interrupted.
7. If you are using the startup/restart interlock operating mode, test whether the lock is enabled when the power is turned on and after the protection field is interrupted.



#### **Warning!**

Danger to life due to unexpected machine startup if the startup/restart interlock is incorrectly set up

If the startup/restart interlock does not function correctly when the power is switched on and after the protection field is interrupted, this can lead to an unexpected dangerous startup of the machine.

Before commissioning the machine, check whether the startup/restart interlock is functioning correctly when the power is connected and following interruption of the protection field.

8. Check the function of the test input when the protection field is clear by applying 24 V to the test input.

↳ The OSSDs switch off and switch the OSSDs back on again after the test has been completed successfully.

If the function "Relay monitor" is activated, the monitored switching elements following the OSSDs accordingly.

## 5.2 Multiple Positions



### **Note!**

If several safety light curtains/safety light grids are operating close to each other, care must be taken to prevent any cross-talk. You can use the operating modes "A" and "B" to prevent cross-talk.

The illustration below shows a preferred layout.

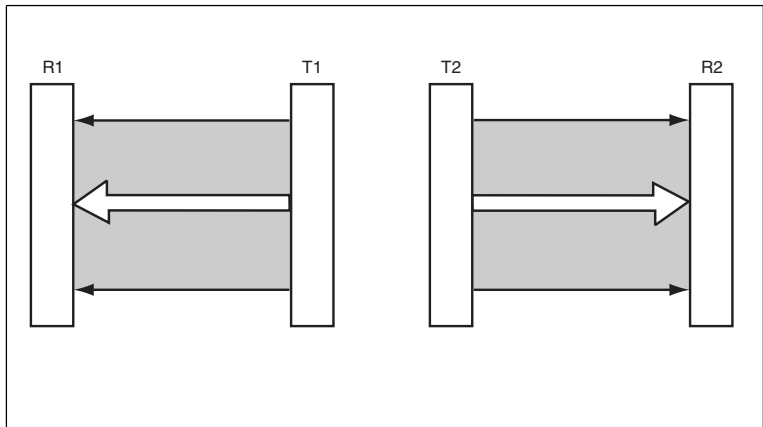

Figure 5.1 Multiple assignment



### **Warning!**

Danger to life due to interference from multiple photoelectric protective devices

If you use several pieces of photoelectric protective equipment in your plant, these may interfere with each other if positioned too close together. The resulting malfunction may result in a failure to detect persons or objects, or in OSSDs switching off unintentionally.

- When using multiple items of photoelectric protective equipment, ensure during the planning stage and before commissioning that cross-talk is prevented.
- Optically shield the protective equipment devices from each other, if necessary using structural methods.
- Prevent optically active objects such as lenses or filters from entering the beam path.
- Ensure that structural methods cannot subsequently become ineffective.

When operating two safety light curtains with different modes A and B, another arrangement is possible by positioning the transmitters and receivers directly on top of each other. The connector plugs extend outwards in the opposite direction. The SLCS30 therefore provides a continuous protection field that is divided as a special feature into two security areas. Suitable devices for head-to-head mounting: standard detection range, resolution 30 mm, 60 mm, or 90 mm and protection field height of maximum 1200 mm per strip. The height of the continuous protection field can therefore reach a maximum of 2400 mm.



**Note!**

This layout is not available for the device option with increased detection range (SLCS\*/35).

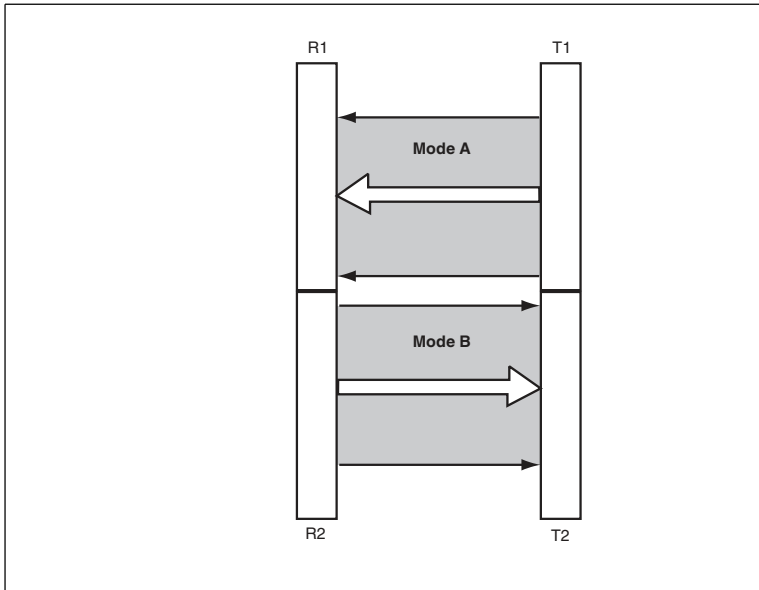

Figure 5.2 Head-to-head layout

## 6 Maintenance and Repair

### 6.1 Maintenance

The safety light curtain is maintenance free.

The prescribed periodic checks must be carried out and documented. The checks to determine whether the components are fitted securely and whether the optical surfaces are clean are important.

See chapter 6.2



#### **Note!**

Use a soft, lint-free cloth to clean the surfaces and to cover the lenses. Only use alcohol or mineral spirits as cleaning fluids. Avoid the use of any other cleaning agents, as they may damage or impair the lens surfaces.

### 6.2 Periodic Checks

The test intervals and scope of the periodic checks are determined according to requirements.

Record the results of periodic check in accordance with the applicable regulations.



#### Daily Check

1. Secure the machine or plant against unintentional startup before and during the checks.
2. Make sure the protection field is clear.
3. Activate the startup enable.
4. Interrupt the protection field inside the protection field range using the test rod. A test rod with a suitable obstacle size must be used.
5. Check the entire protection field at several points parallel to the transmitter or receiver, in particular in front of the transmitter and receiver and in the center between the transmitter and receiver, to find any detection gaps caused by reflective surfaces.

↳ The OSSD outputs switch off.

6. Slowly move the test rod through the protection field while watching the displays on the receiver:

↳ If the startup/restart interlock is **activated**: the yellow startup readiness display does **not** light up.

If the startup/restart interlock is **deactivated**: the green status indicator of the OSSD display does **not** light up.

7. Remove the test rod from the protection field while watching the displays on the receiver:

↳ If the startup/restart indicator is **activated**: the yellow startup readiness indicator lights up.  
If the startup/restart interlock is **deactivated**: the green status display of the OSSD display lights up.

8. When the startup/restart interlock is activated, press the startup enable.

↳ The green OSSD display lights up.



**Warning!**

Danger to life due to missing safety functions

If the protective equipment is not taken into account when checking the safety functions of the whole plant, it is possible that it may no longer function safely together with the other components.

- The protective equipment must be included in any general checks on machine safety functions.
- This includes checking for proper alignment and installation.
- In addition, adherence to the required response times must be tested.

### 6.3

### Repairs

The device must not be repaired, changed, or manipulated. In case of failure, always replace the device with an original device.



**Danger!**

Danger to life from using damaged or repaired devices.

Using a defective or repaired device can compromise its function and its electrical safety.

- Do not use a damaged or polluted device.
- The device must not be repaired, changed or manipulated.
- If there is a defect, always replace the device with an original device from Pepperl+Fuchs.

## 7 Troubleshooting

### 7.1 Troubleshooting



**Warning!**

Danger to life due to an absence of safety functions in the event of dangerous failure

If a device has failed so dangerously that one or more safety functions can no longer be guaranteed, the operational safety of the affected machine or plant is impaired as a consequence.

- Decommission the affected machine or plant and the sensor system and secure them to prevent recommissioning.
- Replace the defective device with an original device from Pepperl+Fuchs.
- Send the defective device to Pepperl+Fuchs with a description of the fault.



**Warning!**

Danger to life as the result of an absence of functional inspections

If you resolve a fault and do not subsequently check whether the device and the protective function it enables are functioning correctly, this can prevent the protective equipment from working.

- After resolving the error, carry out a functional inspection to ensure that the protective equipment is functioning again correctly.
- Repeat the test steps described for commissioning. See chapter 5.

If a fault occurs, press the test contact (Reset). The receiver clears the fault state by performing a system reset.

If this process does not correct the fault, attempt to return to normal mode by switching off the power supply for at least 1 second, then switching it back on again.

#### Eliminating Interference

Source of fault	Cause	Action
<b>Transmitter:</b> Status indicator flashes at 1 Hz	External fault: a) Test signal faulty b) A/B mode input error	a) Check test sequence b) Check wiring A/B input mode
<b>Transmitter:</b> Status indicator flashes at 5 Hz	Internal error	Briefly interrupt power supply or press the restart button. If the error occurs again, send for repair.
<b>Receiver:</b> Status indicator flashes at 5 Hz	Internal error	Briefly interrupt power supply or press the restart button for approx. 1.5 s. If the error occurs again, send for repair.
<b>Receiver:</b> Status indicator flashes at 2.5 Hz	insufficient functional reserve	Clean the front panels; adjust the transmitter and receiver.

Source of fault	Cause	Action
<b>Receiver:</b> Status indicator flashes at 1 Hz	External error: a) Relay monitor error b) Low voltage c) A/B mode input error d) OSSD error	a) Check relay monitor connection b) Check the supply voltage c) Check A/B input mode wiring d) Check the OSSDs for crossed or short circuits
<b>Receiver:</b> OSSD status LED lights up red	Beam interrupted or adjustment error	Remove object from protection field or adjust transmitters and receivers.
<b>Receiver:</b> "Ready to start" status indicator cannot be acknowledged	Faulty restart button connection	Check restart connection

## 8 Appendix

### 8.1 Technical Data

#### General data

	SLCS* Standard sensing range	SLCS*/35 Increased sensing range
Effective operating distance	0.4 m ... 8 m	5 m ... 20 m
Light source	IRED	IRED
Light type	Infrared, modulated light, 850 nm	Infrared, modulated light, 850 nm
LED risk group designation	Free group in accordance with DIN EN 62471	Free group in accordance with DIN EN 62471
Protection field height	See chapter 8.2	See chapter 8.2
Operating mode	Start/restart interlock, can be disabled	Start/restart interlock, can be disabled
Detectable obstacle size (resolution)	SLCS14: 14 mm; SLCS30: 30 mm; SLCS60: 60 mm; SLCS90: 90 mm	SLCS30: 30 mm; SLCS60: 60 mm; SLCS90: 90 mm
Opening angle	< 5 °	< 5 °
Ambient light limit	Immune to ambient light, conforming to EN 61496-2	Immune to ambient light, conforming to EN 61496-2

#### Indicators/operating controls

	SLCS* Standard sensing range	SLCS*/35 Increased sensing range
Operating indicator	Green: power on	Green: power on
Function indicator	Green: OSSD ON, red: OSSD OFF	Green: OSSD ON, red: OSSD OFF
Status indicator	Transmitter: LED yellow: mode, test or fault Receiver: LED yellow: ready to start, functional reserve or fault	Transmitter: LED yellow: mode, test or fault Receiver: LED yellow: ready to start, functional reserve or fault

### Electrical data

	SLCS* Standard sensing range	SLCS*/35 Increased sensing range
Operating voltage	24 VDC (-20%, +30%); power supply with safe isolation: 24 VDC The upstream power supply for a safety light curtain must be capable of withstanding power failures of up to 20 ms.	24 VDC (-20%, +30%); power supply with safe isolation: 24 VDC The upstream power supply for a safety light curtain must be capable of withstanding power failures of up to 20 ms.
No-load current	Transmitter: ≤ 150 mA Receiver: ≤ 150 mA (without outputs)	Transmitter: ≤ 150 mA Receiver: ≤ 150 mA (without outputs)
Power consumption	Transmitter: 5 W receiver: 15 W	Transmitter: 5 W receiver: 15 W
Protection class	III, IEC 61140	III, IEC 61140

### Inputs on the transmitter

	SLCS* Standard sensing range	SLCS*/35 Increased sensing range
<b>Emitter test</b>		
Input format	NC contact	NC contact
Switching voltage	24 VDC (acting on the contact)	24 VDC (acting on the contact)
Input current	5 mA	5 mA
Actuation time	0.02 s ... 2.4 s	0.02 s ... 2.4 s
<b>A/B emitter mode</b>		
Function	Mode A: open or 0 V Mode B: 24 VDC, 5 mA	Mode A: open or 0 V Mode B: 24 VDC, 5 mA

### Inputs on the receiver unit

	SLCS* Standard sensing range	SLCS*/35 Increased sensing range
<b>Relay monitor receiver unit</b>		
Input format	NC contact	NC contact
Switching voltage	24 VDC (acting on the contact)	24 VDC (acting on the contact)
Input current	5 mA	5 mA
Actuation time	< 200 ms	< 200 ms
<b>Startup enable receiver unit</b>		
Input format	NC contact	NC contact
Switching voltage	24 VDC (acting on the contact)	24 VDC (acting on the contact)
Input current	5 mA	5 mA

	SLCS* Standard sensing range	SLCS*/35 Increased sensing range
Actuation time	0.2 s... 1.2 s	0.2 s... 1.2 s

**A/B mode receiver unit (see emitter mode A/B)**

Function	Mode B: 24 VDC, 5 mA	Mode B: 24 VDC, 5 mA
----------	----------------------	----------------------

**Outputs on the receiver**

	SLCS* Standard sensing range	SLCS*/35 Increased sensing range
--	---------------------------------	-------------------------------------

**OSSD output**

Output format	PNP semiconductor, monitored for short circuit and crossed circuit	PNP semiconductor, monitored for short circuit and crossed circuit
Switching voltage	ON: $U_B - 2 V$ OFF: $< 1 V$	ON: $U_B - 2 V$ OFF: $< 1 V$
Switching current (max.)	ON: max. 0.1 A OFF: $< 5 \mu A$	ON: max. 0.1 A OFF: $< 5 \mu A$
Load inductance (max.)	1.0 H	1.0 H
Load capacitance (max.)	220 nF	220 nF
Note	The outputs are permanently monitored by short (max. 120 $\mu s$ ) sampling pulses. You must ensure that this has no effect on the downstream circuit.	The outputs are permanently monitored by short (max. 120 $\mu s$ ) sampling pulses. You must ensure that this has no effect on the downstream circuit.

**Signal output**

Output format	PNP, short-circuit proof	PNP, short-circuit proof
Switching current	0.1 A	0.1 A

**Ambient Conditions**

	SLCS* Standard sensing range	SLCS*/35 Increased sensing range
Ambient temperature	-35 °C... 60 °C (-31 °F... 140 °F)	-35 °C... 60 °C (-31 °F... 140 °F)
Storage temperature	-35 °C... 70 °C (-31 °F... 158 °F)	-35 °C... 70 °C (-31 °F... 158 °F)
Relative humidity	Max. 95 %, not condensing	Max. 95 %, not condensing

### Mechanical specifications

	SLCS* Standard sensing range	SLCS*/35 Increased sensing range
Housing length L		
Connection	Transmitter: connector plug M12 x 1, 4-pin Receiver: connector plug; M12 x 1, 8-pin cable cross section min. 0.25 mm <sup>2</sup> cable length max. 50 m	Transmitter: connector plug M12 x 1, 4-pin Receiver: connector plug; M12 x 1, 8-pin cable cross section min. 0.25 mm <sup>2</sup> cable length max. 50 m
Material		
Housing	Extruded aluminum profile, gold anodized	Extruded aluminum profile, gold anodized
Optical face	Plastic disk, clear polycarbonate	Plastic disk, clear polycarbonate
Weight	See chapter 8.2	See chapter 8.2

#### 8.1.1

#### Standards and key data for functional safety



**Note!**

For unlisted versions with the same resolution of the PFH<sub>d</sub> value, the next largest protection field height specified in the table applies.

#### Functional safety data

	SLCS* Standard sensing range	SLCS*/35 Increased sensing range
Safety Integrity Level (SIL)	SIL 3	SIL 3
Performance Level (PL)	PL e	PL e
Category	Cat. 4	Cat. 4
Life time (T <sub>M</sub> )	20 a	20 a
Type	4	4
PFH <sub>d</sub>		
SLCS14-300	1.36E-8	-
SLCS14-600	1.65E-8	-
SLCS14-900	1.94E-8	-
SLCS14-1200	2.23E-8	-
SLCS30-600	1.31E-8	1.37E-8
SLCS30-900	1.43E-8	1.52E-8
SLCS30-1200	1.55E-8	1.67E-8
SLCS30-1800	1.80E-8	1.97E-8
SLCS30-2400	2.04E-8	2.27E-8

	SLCS* Standard sensing range	SLCS*/35 Increased sensing range
SLCS60-1200	1.38E-8	1.44E-8
SLCS60-2400	1.70E-8	1.81E-8
SLCS90-1200	1.33E-8	1.33E-8
SLCS90-2400	1.59E-8	1.59E-8

The  $PFH_d$  values specified apply up to the maximum ambient temperature.  
For unlisted versions with the same resolution of the  $PFH_d$  value, the next largest protection field height specified in the table applies.

### Conformity with standards

Functional safety	ISO 13849-1 ; EN 61508 part1-4
Product standard	EN 61496-1 ; IEC 61496-2

### Approvals and certificates

CE conformity	CE
UL approval	cULus Listed UL File Number E215245
CCC approval	Products with a maximum operating voltage of $\leq 36$ V are not subject to approval and are therefore not assigned a CCC mark.
TÜV approval	TÜV

## 8.2 Profile lengths and mass

Protection field height [mm]	Overall length of the transmitter / receiver unit [mm]	Weight of transmitter / receiver unit [g]
100	219	140
200	319	200
300	419	250
400	519	310
500	619	370
600	719	430
700	819	480
800	919	540
900	1019	600
1000	1119	650
1100	1219	710
1200	1319	760
1300	1425	820
1400	1525	880
1500	1625	940
1600	1725	990
1700	1825	1050
1800	1925	1100
1900	2025	1160
2000	2125	1210
2100	2225	1270
2200	2325	1320
2300	2425	1380
2400	2525	1440

### 8.3 Dimension drawings

**SLCS14\* for protection field height  $\leq 1200$  mm and  
SLCS30\*/35, SLCS60\*/35, SLCS90\*/35 for protection field heights  
 $\leq 2400$  mm**

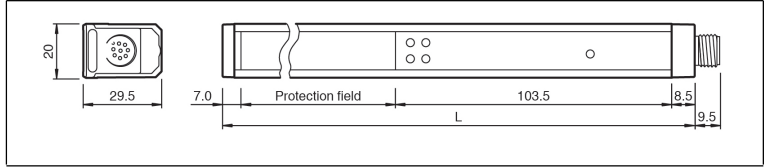

Figure 8.1 Dimensions of the safety light curtain with protection field height  $\leq 1200$  mm and  $\leq 2400$  mm

**SLCS30\*, SLCS60\*, SLCS90\* for protection field heights  $\leq 1200$  mm**

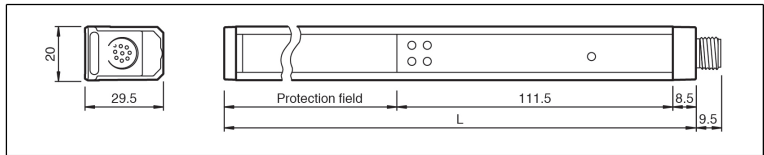

Figure 8.2 Dimensions of the safety light curtain with protection field height  $\leq 1200$  mm

**SLCS30\*, SLCS60\*, SLCS90\* for protection field heights  $\geq 1300$  mm**

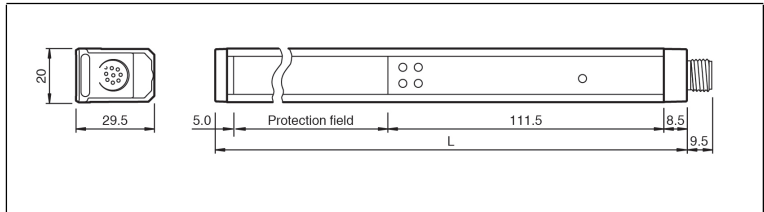

Figure 8.3 Dimensions of the safety light curtain with protection field height  $\geq 1300$  mm

8.4

Type code

**Safety light curtains from the SLCS series are designated by a code according to the following format:**

**S L C S XX - YYYY - Z - AAAA /35**

Here, **XX** represents the obstacle size, **YYYY** the protection field height, **Z** the device type, i.e. transmitter (T) or receiver (R) and **AAAA** a building regulation which applies in individual cases.

"/35" identifies the "increased detection range" option.

Obstacle size	Protectionfield height	Device type	Design specification	Detection range
<b>XX [mm]</b>	<b>YYYY [mm]</b>	<b>Z</b>	<b>AAAA</b>	
14	100, 200, 300, ... 1200	T, R	No specification	Standard
30	100, 200, 300, ... 2400	T, R	No specification	Standard Increased detection range "/35"
60	300, 600, 900, ... 2400	T, R	No specification	Standard Increased detection range "/35"
90	300, 600, 900, ... 2400	T, R	No specification	Standard Increased detection range "/35"

**Type code "SCLS14-\* (obstruction size 14 mm)**

Protection field height [mm]	Complete	Transmitter(-T)	Receiver(-R)
100	SLCS14-100	SLCS14-100 -T	SLCS14-100 -R
200	SLCS14-200	SLCS14-200 -T	SLCS14-200 -R
300	SLCS14-300	SLCS14-300 -T	SLCS14-300 -R
400	SLCS14-400	SLCS14-400 -T	SLCS14-400 -R
500	SLCS14-500	SLCS14-500 -T	SLCS14-500 -R
600	SLCS14-600	SLCS14-600 -T	SLCS14-600 -R
700	SLCS14-700	SLCS14-700 -T	SLCS14-700 -R
800	SLCS14-800	SLCS14-800 -T	SLCS14-800 -R
900	SLCS14-900	SLCS14-900 -T	SLCS14-900 -R
1000	SLCS14-1000	SLCS14-1000 -T	SLCS14-1000 -R
1100	SLCS14-1100	SLCS14-1100 -T	SLCS14-1100 -R
1200	SLCS14-1200	SLCS14-1200 -T	SLCS14-1200 -R

271694 2017-11

**Type code "SCLS30-\* (obstruction size 30 mm) - standard detection range**

Protection field height [mm]	Complete	Transmitter(-T)	Receiver(-R)
100	SLCS30-100	SLCS30-100 -T	SLCS30-100 -R
200	SLCS30-200	SLCS30-200 -T	SLCS30-200 -R
300	SLCS30-300	SLCS30-300 -T	SLCS30-300 -R
400	SLCS30-400	SLCS30-400 -T	SLCS30-400 -R
500	SLCS30-500	SLCS30-500 -T	SLCS30-500 -R
600	SLCS30-600	SLCS30-600 -T	SLCS30-600 -R
700	SLCS30-700	SLCS30-700 -T	SLCS30-700 -R
800	SLCS30-800	SLCS30-800 -T	SLCS30-800 -R
900	SLCS30-900	SLCS30-900 -T	SLCS30-900 -R
1000	SLCS30-1000	SLCS30-1000 -T	SLCS30-1000 -R
1100	SLCS30-1100	SLCS30-1100 -T	SLCS30-1100 -R
1200	SLCS30-1200	SLCS30-1200 -T	SLCS30-1200 -R
1300	SLCS30-1300	SLCS30-1300 -T	SLCS30-1300 -R
1400	SLCS30-1400	SLCS30-1400 -T	SLCS30-1400 -R
1500	SLCS30-1500	SLCS30-1500 -T	SLCS30-1500 -R
1600	SLCS30-1600	SLCS30-1600 -T	SLCS30-1600 -R
1700	SLCS30-1700	SLCS30-1700 -T	SLCS30-1700 -R
1800	SLCS30-1800	SLCS30-1800 -T	SLCS30-1800 -R
1900	SLCS30-1900	SLCS30-1900 -T	SLCS30-1900 -R
2000	SLCS30-2000	SLCS30-2000 -T	SLCS30-2000 -R
2100	SLCS30-2100	SLCS30-2100 -T	SLCS30-2100 -R
2200	SLCS30-2200	SLCS30-2200 -T	SLCS30-2200 -R
2300	SLCS30-2300	SLCS30-2300 -T	SLCS30-2300 -R
2400	SLCS30-2400	SLCS30-2400 -T	SLCS30-2400 -R

**Type code "SCLS30-\* (obstruction size 30 mm) - increased detection range**

Protection field height [mm]	Complete	Transmitter(-T)	Receiver(-R)
100	SLCS30-100/35	SLCS30-100-T/35	SLCS30-100-R/35
200	SLCS30-200/35	SLCS30-200-T/35	SLCS30-200-R/35
300	SLCS30-300/35	SLCS30-300-T/35	SLCS30-300-R/35
400	SLCS30-400/35	SLCS30-400-T/35	SLCS30-400-R/35
500	SLCS30-500/35	SLCS30-500-T/35	SLCS30-500-R/35
600	SLCS30-600/35	SLCS30-600-T/35	SLCS30-600-R/35

Protection field height [mm]	Complete	Transmitter(-T)	Receiver(-R)
700	SLCS30-700/35	SLCS30-700-T/35	SLCS30-700-R/35
800	SLCS30-800/35	SLCS30-800-T/35	SLCS30-800-R/35
900	SLCS30-900/35	SLCS30-900-T/35	SLCS30-900-R/35
1000	SLCS30-1000/35	SLCS30-1000-T/35	SLCS30-1000-R/35
1100	SLCS30-1100/35	SLCS30-1100-T/35	SLCS30-1100-R/35
1200	SLCS30-1200/35	SLCS30-1200-T/35	SLCS30-1200-R/35
1300	SLCS30-1300/35	SLCS30-1300-T/35	SLCS30-1300-R/35
1400	SLCS30-1400/35	SLCS30-1400-T/35	SLCS30-1400-R/35
1500	SLCS30-1500/35	SLCS30-1500-T/35	SLCS30-1500-R/35
1600	SLCS30-1600/35	SLCS30-1600-T/35	SLCS30-1600-R/35
1700	SLCS30-1700/35	SLCS30-1700-T/35	SLCS30-1700-R/35
1800	SLCS30-1800/35	SLCS30-1800-T/35	SLCS30-1800-R/35
1900	SLCS30-1900/35	SLCS30-1900-T/35	SLCS30-1900-R/35
2000	SLCS30-2000/35	SLCS30-2000-T/35	SLCS30-2000-R/35
2100	SLCS30-2100/35	SLCS30-2100-T/35	SLCS30-2100-R/35
2200	SLCS30-2200/35	SLCS30-2200-T/35	SLCS30-2200-R/35
2300	SLCS30-2300/35	SLCS30-2300-T/35	SLCS30-2300-R/35
2400	SLCS30-2400/35	SLCS30-2400-T/35	SLCS30-2400-R/35

**Type code "SCLS60-\* (obstruction size 60 mm) - standard detection range**

Protection field height [mm]	Complete	Transmitter(-T)	Receiver(-R)
300	SLCS60-300	SLCS60-300 -T	SLCS60-300 -R
600	SLCS60-600	SLCS60-600 -T	SLCS60-600 -R
900	SLCS60-900	SLCS60-900 -T	SLCS60-900 -R
1200	SLCS60-1200	SLCS60-1200 -T	SLCS60-1200 -R
1500	SLCS60-1500	SLCS60-1500 -T	SLCS60-1500 -R
1800	SLCS60-1800	SLCS60-1800 -T	SLCS60-1800 -R

2716942017-11

Protection field height [mm]	Complete	Transmitter(-T)	Receiver(-R)
2100	SLCS60-2100	SLCS60-2100 -T	SLCS60-2100 -R
2400	SLCS60-2400	SLCS60-2400 -T	SLCS60-2400 -R

**Type code "SCLS60-\* (obstruction size 60 mm) - increased detection range**

Protection field height [mm]	Complete	Transmitter(-T)	Receiver(-R)
300	SLCS60-300/35	SLCS60-300-T/35	SLCS60-300-R/35
600	SLCS60-600/35	SLCS60-600-T/35	SLCS60-600-R/35
900	SLCS60-900/35	SLCS60-900-T/35	SLCS60-900-R/35
1200	SLCS60-1200/35	SLCS60-1200-T/35	SLCS60-1200-R/35
1500	SLCS60-1500/35	SLCS60-1500-T/35	SLCS60-1500-R/35
1800	SLCS60-1800/35	SLCS60-1800-T/35	SLCS60-1800-R/35
2100	SLCS60-2100/35	SLCS60-2100-T/35	SLCS60-2100-R/35
2400	SLCS60-2400/35	SLCS60-2400-T/35	SLCS60-2400-R/35

**Type code "SCLS90-\* (obstruction size 90 mm) - standard detection range**

Protection field height [mm]	Complete	Transmitter(-T)	Receiver(-R)
300	SLCS90-300	SLCS90-300 -T	SLCS90-300 -R
600	SLCS90-600	SLCS90-600 -T	SLCS90-600 -R
900	SLCS90-900	SLCS90-900 -T	SLCS90-900 -R
1200	SLCS90-1200	SLCS90-1200 -T	SLCS90-1200 -R
1500	SLCS90-1500	SLCS90-1500 -T	SLCS90-1500 -R
1800	SLCS90-1800	SLCS90-1800 -T	SLCS90-1800 -R
2100	SLCS90-2100	SLCS90-2100 -T	SLCS90-2100 -R
2400	SLCS90-2400	SLCS90-2400 -T	SLCS90-2400 -R

**Type code "SCLS90-\* (obstruction size 90 mm) - increased detection range**

Protection field height [mm]	Complete	Transmitter(-T)	Receiver(-R)
300	SLCS90-300/35	SLCS90-300-T/35	SLCS90-300-R/35
600	SLCS90-600/35	SLCS90-600-T/35	SLCS90-600-R/35
900	SLCS90-900/35	SLCS90-900-T/35	SLCS90-900-R/35

Protection field height [mm]	Complete	Transmitter(-T)	Receiver(-R)
1200	SLCS90-1200/35	SLCS90-1200-T/35	SLCS90-1200-R/35
1500	SLCS90-1500/35	SLCS90-1500-T/35	SLCS90-1500-R/35
1800	SLCS90-1800/35	SLCS90-1800-T/35	SLCS90-1800-R/35
2100	SLCS90-2100/35	SLCS90-2100-T/35	SLCS90-2100-R/35
2400	SLCS90-2400/35	SLCS90-2400-T/35	SLCS90-2400-R/35

## 8.5 Application Checklist

A list of important points should help you avoid errors when planning, setting up, and using the protective device. This application checklist is not complete and must be modified to suit each specific application.



### **Note!**

#### **Observing Applicable Standards and Laws**

The relevant laws and standards that apply to the use of opto-electronic safety devices must be followed. There are differences depending on the area of use.

#### **Before Installation**

- Have all the applicable standards and regulations been observed?
- Does the technical data of the SLCS meet the requirements of the application? This especially applies to detection capability, the protection field height, and the operating voltage.
- Is the overvoltage category required by EN 50178 or EN 60947-1 met at the connections?
- Is the electrical equipment, the wiring and the overcurrent protection designed in accordance with IEC 60204-1:2009?
- Is there enough space for fitting and dismantling components?
- Are the distances between the protection field and the hazardous area as well as the reflective surfaces maintained as required?
- Is the SLCS used indoors?

#### **After Installation**

- Is the startup enable input connected when the startup/restart interlock is activated?
- Is the ready to start signal lamp connected?
- Is the test input connected?
- Is the red/green indicator for signaling the status of the OSSD outputs in a visible location?
- Are all components correctly connected?
- Has the SLCS been positioned so that the protection field cannot be bypassed and people cannot enter the hazardous area undetected?
- Is the SLCS aligned?
- Have the necessary safety distances been maintained?

#### **Commissioning**

- Has the detection capability of the SLCS been tested over the entire protection field height using the test rod? This test should take place at multiple locations and at least once in front of the transmitter and receiver as well as at the central point between the transmitter and receiver.
- Do the OSSD switch outputs trigger the requisite stop?
- Has the response time of the overall protective device been checked?

#### **Periodic Inspection**





- Have the requisite tests and test intervals been determined?



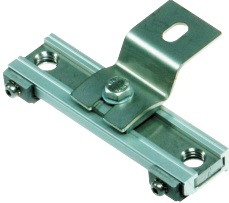

- Is the detection capability of the SLCS tested regularly over the entire protection field height using the test rod?
- Are the response times checked at regular intervals?
- Is all machine safety equipment inspected at the required intervals?
- Are all inspections documented?

## 8.6 Accessories

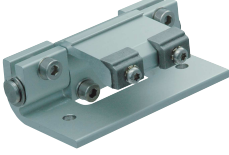
The following products are available as accessories:



### Matching accessories for safety light curtains



No.	Designation	Illustration	Description
1	OMH-SLCT-01		Mounting Aid
2	OMH-SLCT-02		Mounting Aid
3	OMH-SLCT-03		Mounting Aid
4	OMH-SLCT-04		Mounting Aid
5	OMH-SLCT-05		Mounting Aid

No.	Designation	Illustration	Description
6	OMH-SLCT-10		Mounting Aid
7	OMH-SLCT-11		Mounting Aid
8	OMH-SLCT-12-500		Muting arm with round rod
9	OMH-07-01		Light barrier holder for muting round rod

No.	Designation	Illustration	Description
10	OMH-SLCT-100-1200		Mounting profile for floor mounting
	OMH-SLCT-100-1500		
	OMH-SLCT-100-2100		
	OMH-SLCT-100-2500		

No.	Designation	Illustration	Description
11	OMH-SLCT-110-1200		Mounting profile with decorative cover (front)
	OMH-SLCT-110-1500		
	OMH-SLCT-110-2100		
	OMH-SLCT-110-2500		

No.	Designation	Illustration	Description
12	OMH-SLCT-120-1200 OMH-SLCT-120-1500 OMH-SLCT-120-2100 OMH-SLCT-120-2500		Two lateral protective covers for mounting profile
13	OMH-SLCT-200		Floor mount for soil column/mounting profile

No.	Designation	Illustration	Description
14	SLCT-M-01-1200		Inclined mirror for 90° deflection
	SLCT-M-01-1500		
	SLCT-M-01-2100		
	SLCT-M-01-2500		
15	AA SLCT-01		Profile alignment aid
16	TR 14/30/50/60		Test rod

271694.2017-11

### Available Mounting Brackets

The mounting brackets enable light curtains and accessories to be mounted. A complete mounting bracket is required to mount a transmitter and a receiver. The mounting brackets are also suitable as a corner profile if two independently acting light curtains are to be installed. For compatible mounting brackets, use the search term *SLCT-M\** on [www.pepperl+fuchs.com](http://www.pepperl+fuchs.com).

#### 8.6.1 Mounting Aid OMH-SLCT-01

##### Model number: OMH-SLCT-01

The transmitters/receivers can be secured using mounting aids that grip the dovetail guide. Dovetail guides are located on three sides of the profile. When mounting and aligning the unit, avoid subjecting the profile to mechanical tension.

A minimum of two mounting aids must be used to secure the transmitter and receiver unit. If vibrations or shocks are expected, we recommend attaching mounting aids at intervals of 500 mm.

#### 8.6.2 Mounting Aid OMH-SLCT-02

##### Model number: OMH-SLCT-02

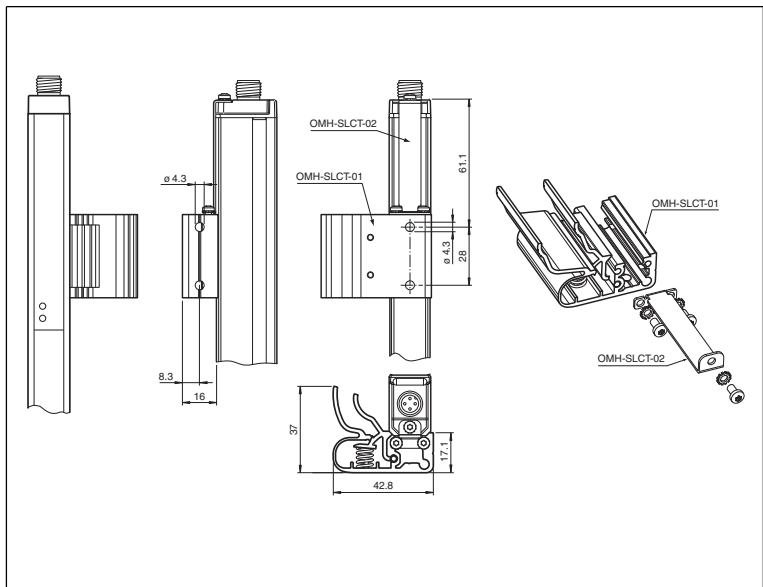

Figure 8.4 Dimensional drawing and assembly of the mounting aids OMH-SLCT-01 and OMH-SLCT-02

The OMH-SLCT-02 mounting aid is used as a fixed bearing and secures the position of the light curtain in the event of thermal expansion, vibration, or shock.

### 8.6.3 Mounting brackets OMH-SLCT-03 and OMH-SLCT-04

**Model number (fixed bearing): OMH-SLCT-03**

**Model number (movable bearing): OMH-SLCT-04**

The longer mounting aid OMH-SLCT-03 has a higher clamping force than the shorter mounting aid OMH-SLCT-04 and is therefore the preferred option for assuming the function of the fixed bearing. A minimum of one fixed bearing and one movable bearing is required to mount the device. If more than two mounting aids are required for reasons of stability, the use of additional movable bearings is recommended. If vibrations or shocks are expected, we recommend attaching mounting aids at intervals of 500 mm.

The mounting aid OMH-SLCT-03 can also be used to connect 2 safety light curtains or safety light grids. If the mounting aid is to be used for this application, the metal bracket should be removed.

### 8.6.4 Mounting Aid OMH-SLCT-05

**Model number: OMH-SLCT-05**

The OMH-SLCT-05 mounting aid is a robust, swiveling holder with very large pivoting range. The integrated dovetail groove terminal device enables the mounting of profiles from the SLCS or SLCT series without any additional accessories.

#### Features

- Large pivoting range from  $-7^{\circ}$  ..  $+110^{\circ}$
- Very robust
- Easily accessible screws
- Integrated dovetail groove for mounting SLCS or SLCT

### 8.6.5 OMH-SLCT-12 -500 Muting arm with round rod

Mounting bracket, muting arm with round rod  $d=12$  mm

- Can be attached to groove in two directions
- Fast assembly

### 8.6.6 OMH-07-01 Mounting bracket for circular profiles

Mounting bracket for circular profiles  $\varnothing 12$  mm or flat profiles 1.5 mm ... 3 mm

### 8.6.7 OMH-SLCT-100-xxxx Mounting profile for floor mounting

- Eight grooves for mounting photoelectric sensors or accessories, three on the inside and five on the outside
- Corner mounting of photoelectric sensors with a directional difference of  $90^{\circ}$
- Cover prepared for indicator light mounting

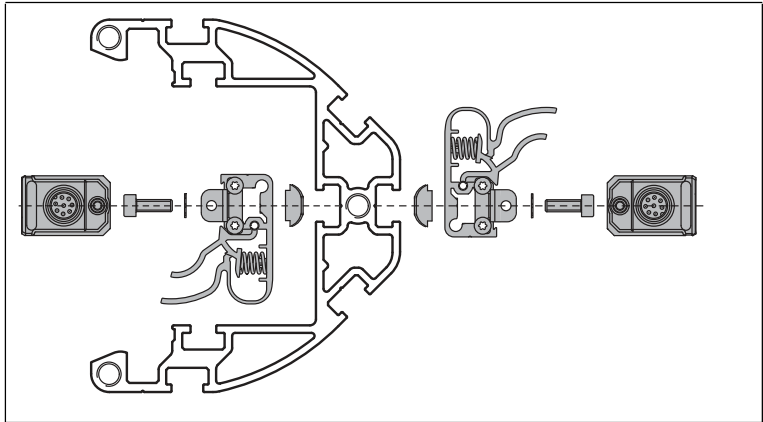

Figure 8.5 Example of mounting a mounting aid OMH-SLCT-01 to a mounting column

### 8.6.8 OMH-SLCT-110-xxx Mounting profile with decorative cover (front)

Mounting base for floor mounting with rear panel and cover plate

- Eight grooves for mounting photoelectric sensors or accessories, three on the inside and five on the outside
- Corner mounting of photoelectric sensors with a directional difference of 90°
- Cover prepared for indicator light mounting
- Rear panel prepared for 3 sensors and 6 cable glands

### 8.6.9 OMH-SLCT-120-xxx Lateral protective covers for mounting profile

Lateral protection for the OMH-SLCT-100 and OMHSLCT- 110 mounting bases

### 8.6.10 OMH-SLCT-200 Floor mount for soil column/mounting profile

#### Features

- Rotation of the SLCT-M- 01 inclined mirror around the physically preferred rotational axis
- Vertical adjustment decoupled from rotation
- Mounting on ground anchors
- Lead-away of lines in floor via hole for NW29 coupling nut and corrugated hose
- Base plate to compensate for uneven ground, particularly for brittle surfaces
- Only approx. 20 mm in height from bottom edge of base plate to top edge of ground plate

### 8.6.11 SLCT-M-01-xxxx inclined mirror for 90° deflection

#### Features

- Rotation-invariant deflection of a light beam by 90° in the plane of incidence, making it highly vibration-resistant

- Translation-free deflection with no lateral beam shift with OMH-SLCT-200 floor mount
- Silver-coated mirror glass
- Mirror glass with low light absorption
- Up to Ø 48 mm pencil of rays in the plane of incidence

### 8.6.12

#### Alignment aid

##### Order code: AA-SLCT-01

The transmitter and receiver should always be aligned at the same height in parallel to one another. The AA-SLCT-01 alignment aid with bubble level assists the perpendicular alignment of the profile. The AA-SLCT-01 alignment aid is simply clipped into the groove on the side of the profile.

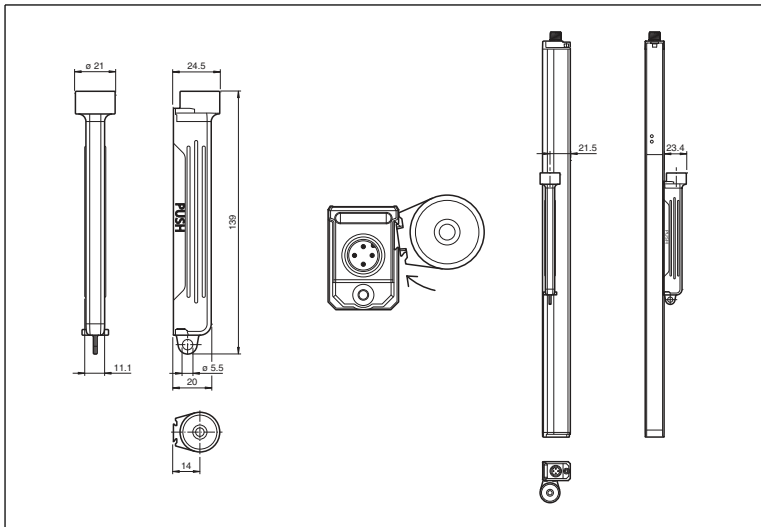

Figure 8.6 Dimensional drawing and assembly of the alignment AA-SLCT-01

### 8.6.13

#### Test rod

##### Order designation: TR 14/30/50/60

The detection capability of a safety light curtain should be checked regularly using a test rod. The test rod must be kept in the same location as the safety light curtain. At regular prescribed intervals, the protection field must be tested at different points over its entire height (in front of the transmitter and receivers and in the center between the transmitter and receiver) and the results must be documented.

The receiver of every safety light curtain comes with a test rod 230 mm in length. The rod is suitable for checking the detection capability of light curtains with different resolutions.

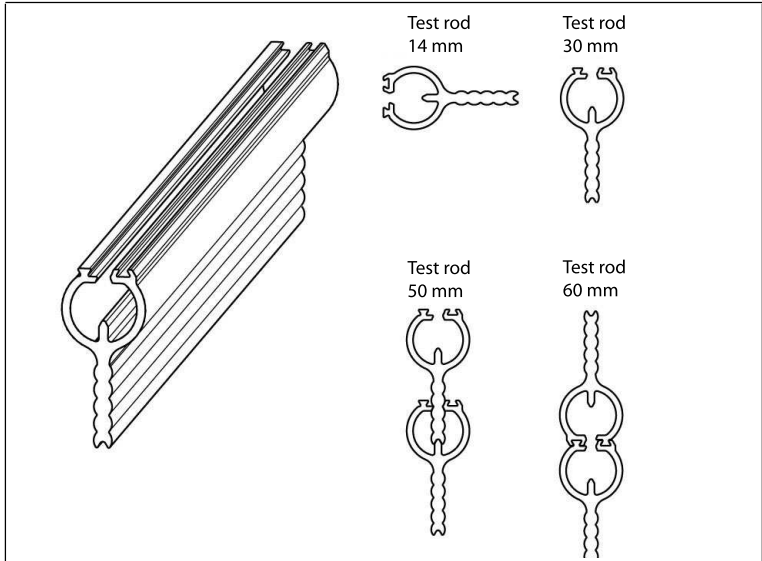

Figure 8.7 TR 14/30/50/60 test rod

### 8.6.14 Connection Cables

Various 4-pin and 8-pin connection cables are available in a range of lengths. Connection cables are not included in the scope of delivery of a safety light curtain.

#### Connection cable for safety light curtains

Use	Model number		
	Length 2 m	Length 5 m	Length 10 m
4-pin cable (transmitter)	V1-G-BK2M-PUR-UL	V1-G-BK5M-PUR-UL	V1-G-BK10M-PUR-UL
8-pin cable (receiver)	V19-G-BK2M-PUR	V19-G-BK5M-PUR	V19-G-BK10M-PUR

The specified cables are UL-certified and marked accordingly.

# FACTORY AUTOMATION – SENSING YOUR NEEDS



## Worldwide Headquarters

Pepperl+Fuchs GmbH  
68307 Mannheim · Germany  
Tel. +49 621 776-0  
E-mail: [info@de.pepperl-fuchs.com](mailto:info@de.pepperl-fuchs.com)

## USA Headquarters

Pepperl+Fuchs Inc.  
Twinsburg, Ohio 44087 · USA  
Tel. +1 330 4253555  
E-mail: [sales@us.pepperl-fuchs.com](mailto:sales@us.pepperl-fuchs.com)

## Asia Pacific Headquarters

Pepperl+Fuchs Pte Ltd.  
Company Registration No. 199003130E  
Singapore 139942  
Tel. +65 67799091  
E-mail: [sales@sg.pepperl-fuchs.com](mailto:sales@sg.pepperl-fuchs.com)

[www.pepperl-fuchs.com](http://www.pepperl-fuchs.com)

 **PEPPERL+FUCHS**  
SENSING YOUR NEEDS

Subject to modifications  
Copyright PEPPERL+FUCHS • Printed in Germany

271694

DOCT-3847B

11/2017